



More information on the website  
[radwag.com/en/info,w1,KSB](http://radwag.com/en/info,w1,KSB)

# C315.150.C2.M Load Cell Platform Scale



## Functions



Plus/Minus Control



Percent Weighing



Totalizing



Parts counting



Internal battery



Peak hold



Newton unit measurement



GLP Procedures



Animal weighing



ALIBI Memory

## Datasheet

Metrological parameters	
Maximum capacity [Max]	150 kg
Minimum load	1 kg
Readability [d]	50 g
Tare range	-150 kg
Verification scale interval	50 g
Max readability for non-verified scale	5 g
OIML Class	III

Physical parameters	
Display	LCD (backlit)
Weighing pan dimensions	400×500 mm
Packaging dimensions	720×620×210 mm
Net weight	12,8 kg
Gross weight	14,8 kg
Construction	
Communication interface	
RS232 Interface	1× standard, 1× option
Electrical parameters	
Power supply	100 ÷ 240 V AC 50 / 60 Hz and battery
Power consumption max.	5 W
Operation time on batteries	max 8h
Environmental conditions	
Operating temperature	-10 ÷ +40 °C
Storage temperature	-10 ÷ +50 °C
Relative humidity	10% ÷ 85% RH no condensation
Indicator	C315
Weighing pan material	stainless steel AISI304

\* Wi-Fi® is a registered trademark of Wi-Fi® Alliance.



## Accessories

Receipt Printer  
Cigarette lighter receptacle power supply cables  
Displays  
Granite Antivibration Tables  
RS 232 – Ethernet Converter

RS 232, RS 485 cables  
RS 232 – USB Converter  
RS 232 cables (scale - EPSON printer)  
RS 232 – RS 485 Converter

## Software

RAD-KEY  
LabVIEW Driver  
R-LAB

RW Tool  
R Panel  
Scales Editor 2.0

## Device dimensions

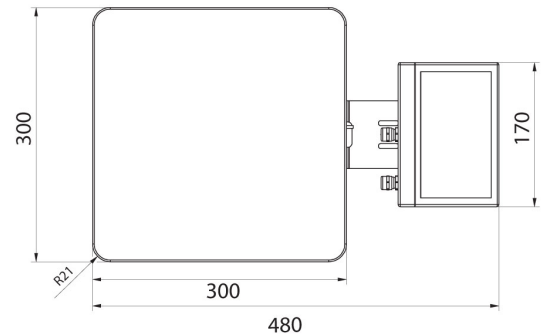
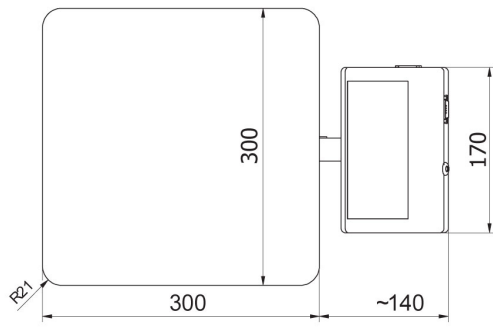
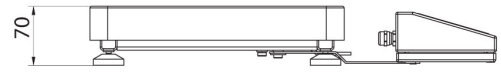
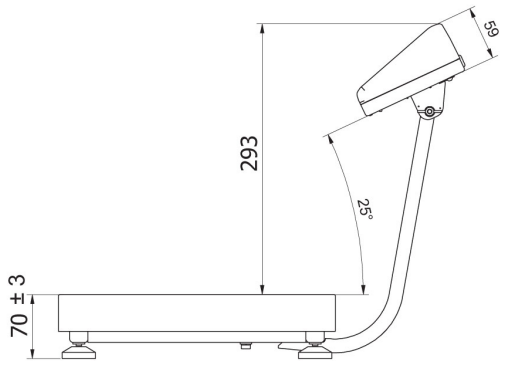

C315.F1.M

C315.F1.R

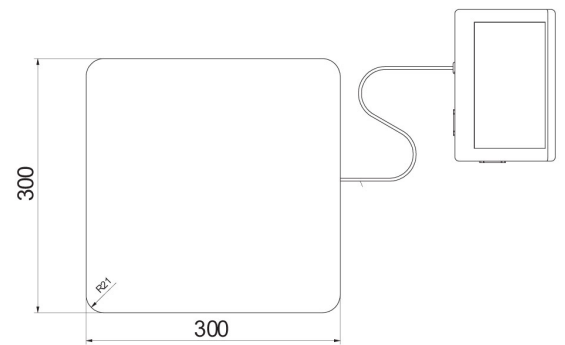
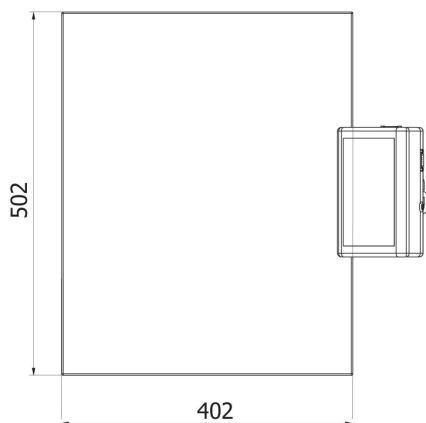
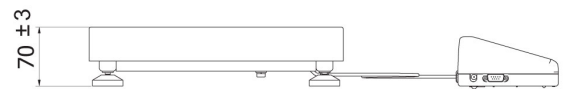
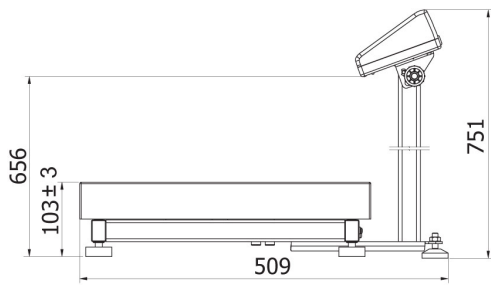

C315.C2.M

C315.C2.K