



More information on the website
radwag.com/en/info,w1,D9K

C315.150.C2.R Load Cell Platform Scale



Functions



Plus/Minus Control



Percent Weighing



Totalizing



Parts counting



Internal battery



Peak hold



Newton unit measurement



GLP Procedures



Animal weighing



ALIBI Memory

Datasheet

| Metrological parameters | |
|--|---------|
| Maximum capacity [Max] | 150 kg |
| Minimum load | 1 kg |
| Readability [d] | 50 g |
| Tare range | -150 kg |
| Verification scale interval | 50 g |
| Max readability for non-verified scale | 5 g |
| OIML Class | III |

| Physical parameters | |
|-----------------------------|---------------------------------------|
| Display | LCD (backlit) |
| Weighing pan dimensions | 400×500 mm |
| Packaging dimensions | 720×580×220 mm |
| Net weight | 12,5 kg |
| Gross weight | 15 kg |
| Construction | |
| Communication interface | |
| RS232 Interface | 1× standard, 1× option |
| Electrical parameters | |
| Power supply | 100 ÷ 240 V AC 50 / 60 Hz and battery |
| Power consumption max. | 5 W |
| Operation time on batteries | max 8h |
| Environmental conditions | |
| Operating temperature | -10 ÷ +40 °C |
| Storage temperature | -10 ÷ +50 °C |
| Relative humidity | 10% ÷ 85% RH no condensation |
| Indicator | C315 |
| Weighing pan material | stainless steel AISI304 |

* Wi-Fi® is a registered trademark of Wi-Fi® Alliance.



Accessories

Receipt Printer
 Granite Antivibration Tables
 Cigarette lighter receptacle power supply cables
 Displays
 RS 232 – Ethernet Converter

AP2-1 Current Loop Unit
 RS 232, RS 485 cables
 RS 232 – USB Converter
 RS 232 cables (scale - EPSON printer)
 RS 232 – RS 485 Converter

Software

RAD-KEY
 LabVIEW Driver
 R-LAB

RW Tool
 R Panel
 Scales Editor 2.0

Device dimensions

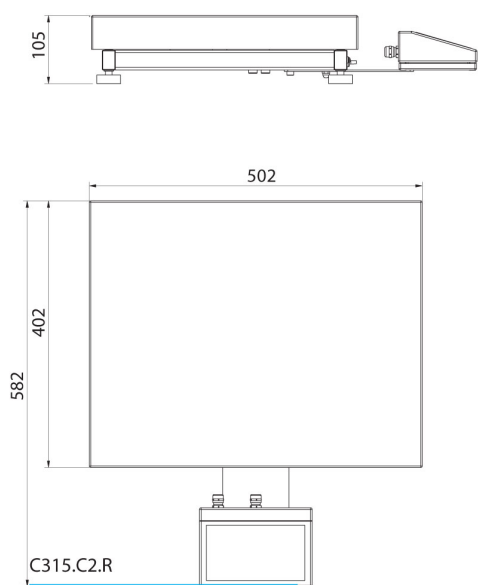

C315.C2.R

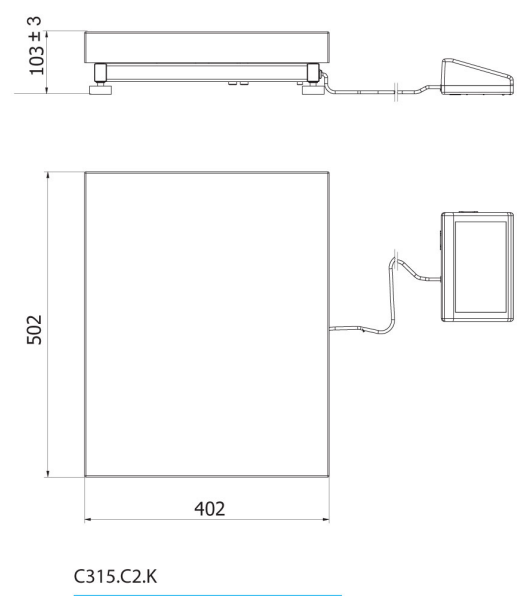

C315.C2.K

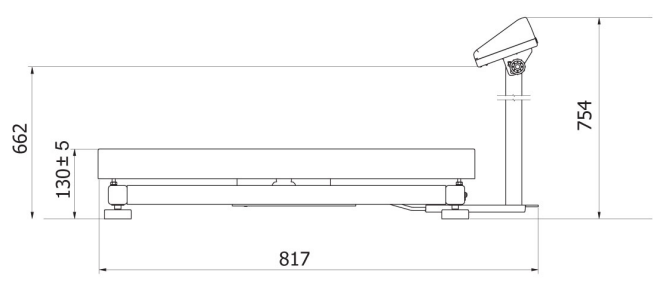

C315.C3.M

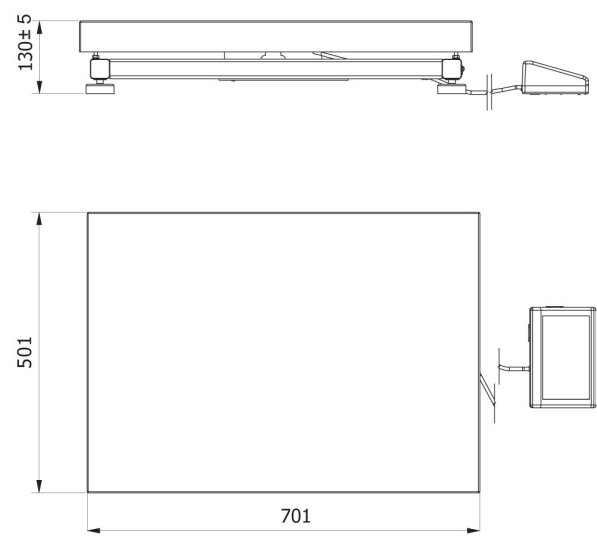

C315.C3.K