

Truflo GI Series Gauge Isolators allow inexpensive pressure gauges, or any other pressure instrument to be used in corrosive services. The upper chamber (gauge side) is filled with a stable fluid such as glycerin or silicone. A Teflon® diaphragm separates it from the lower chamber which receives the media under pressure. Customers can easily fill isolators and install their own gauges.

PVC

PP

PVDF

SERIES : GI

INLET PROCESS CONNECTION : ½" (F) NPT | BSP  
| G | Flange

INSTRUMENT CONNECTION : ¼" NPT | G

DIAPHRAGM : FPM | PTFE Teflon® Bonded EPDM FPM

## FEATURES

### Easy to Mount Gauges

- No Special Equipment is Required.
- Perfect Mate for Truflo OBS Plastic Gauges

### Perfect for Instrumentation Protection

- Eliminates Sediment Build-Up in Gauges
- Available in Different Colors -Personalize your process skid or chemical application
- FPM or PTFE bonded FPM dished diaphragm for High Chemical Resistance and Sensitivity

### Heavy Duty Design for Safety

- Small Footprint
- Heavy Wall Connection Ports-Eliminates need for external bushing



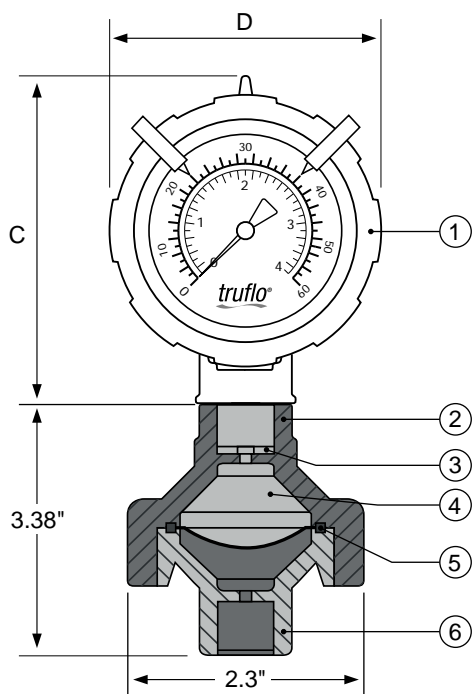

**PARTS**

No.	Part	Materials
1	Pressure Gauge	PP   316 SS
2	Bonnet	PPG   PVDF
3	O-Ring	FPM-G-Thread Only
4	Liquid Fill	Glycerin   Silicone
5	Diaphragm	PTFE Teflon® Bonded EPDM
6	Lower Chamber	PVC   PPG   PVDF

**OPTIONAL GAUGES**

Truflo offers the gauges listed below mounted to isolator and pre-filled with glycerin, silicone or special fluid for chlorine applications. Truflo gauges have a PP plastic housing and the dials and cases are filled with either glycerin or silicone for corrosion resistance and dampening.

Truflo GI gauge isolators are not recommended for vacuum applications.

**OTHER OPTIONS**

Flanged inlet connections

**DIMENSIONS (INCHES)**

Gauge Diameter	Item No.	Gauge Connection	Housing	Bourdon Tube	Window	Accuracy	Dimensions	
							C	D(max.)
2-½"	OBS-xx	¼"	316 SS	316 SS	Polycarbonate	±0.75% of span	3.6	3.1
2-½" Double-Sided	OBS-DGOxx-	¼"	316 SS	316 SS	Polycarbonate	±0.75% of span	3.6	3.1
2-½" Back Mount	OBS--xx-	¼"	316 SS	316 SS	Polycarbonate	±0.75% of span	3.6	3.1
4-½"	OBS4--xx-	¼"	316 SS	316 SS	Polycarbonate	±0.75% of span	6.0	6.0

xx denotes the maximum gauge pressure i.e., 30 | 60 | 100 | 160 psi. See data page for recommended working pressures. Other Ranges are available

**WORKING PRESSURES (psi) \* (Non-Shock)**

**WEIGHTS**

Material	10 – 20°C 50 – 68°F	30°C 86°F	40°C 104°F	50°C 122°F	60°C 140°F	70°C 158°F	80°C 176°F	90°C 194°F	100°C 212°F	120°C 248°F	Net Weights Pounds <sup>3</sup>
PVC	150	100	80	45	15	-	-	-	-	-	1.0
PP	150	125	100	80	65	45	-	-	-	-	0.7
PVDF	150	150	150	125	105	85	70	60	45	30	1.3

Temperature Ranges : PVC 0 to 60°C (32 to 140°F) | PP 10 to 80°C (50 to 176°F) | PVDF -30 to 120°C (-22 to 248°F)

**ORDERING EXAMPLE**

<b>Gauge Isolators</b>	<b>GI</b>	<b>GFPP</b>		<b>F</b>
Body Material	<b>P</b> – PVC	<b>PP</b> – PP	<b>PF</b> – PVDF	
Instrument Connection	<b>(F)</b> FNPT   <b>(FL)</b> ANSI 150			
Instrument Type	<b>(G6)</b> 21/2" Gauge 0-60psi   <b>(G10)</b> 21/2" Gauge 0-100psi   <b>(G16)</b> 21/2" Gauge 0-160 psi <b>(G64)</b> 41/2" Gauge 0-60psi   <b>(G104)</b> 41/2" Gauge 0-100psi   <b>(G164)</b> 41/2" Gauge 0-160psi			